

Z.F.

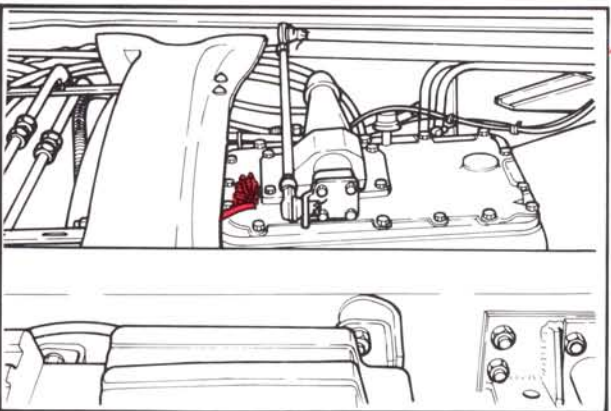

R.T.O.

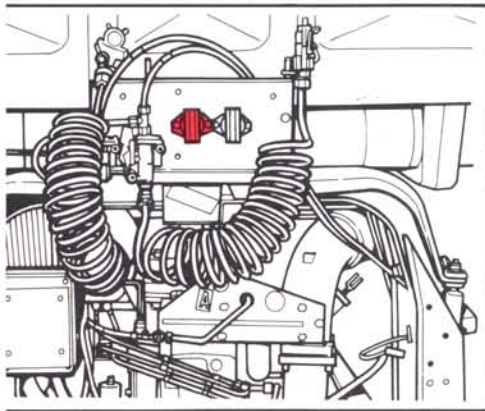

FT

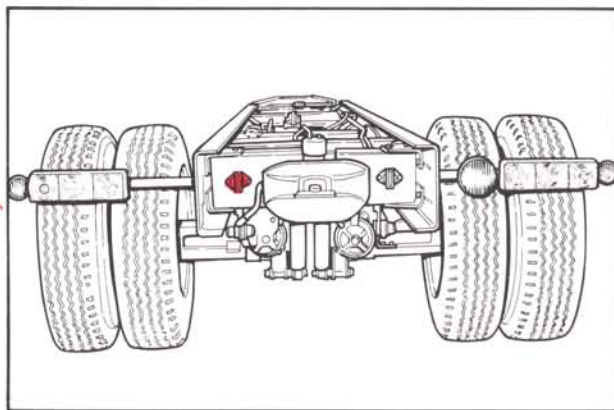
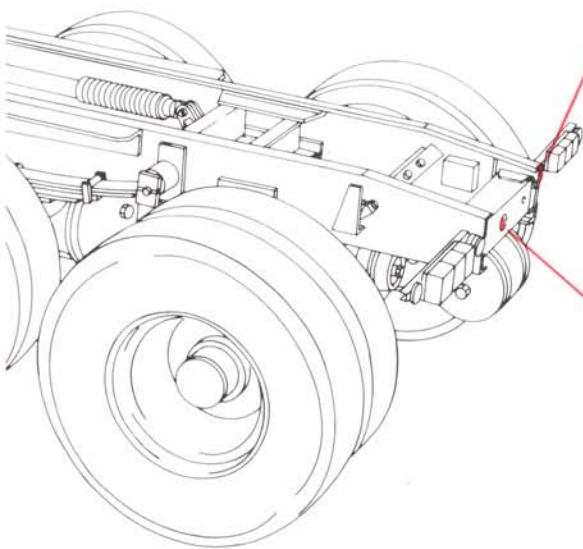
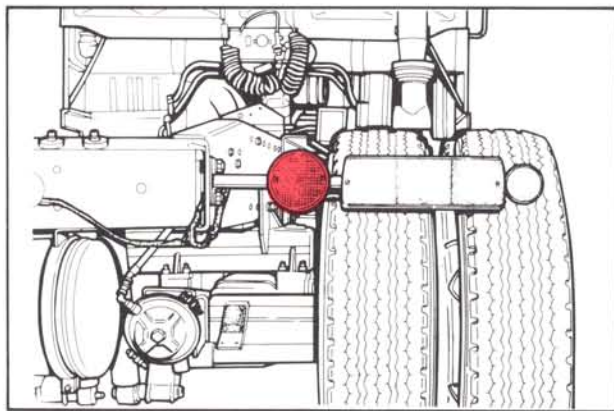
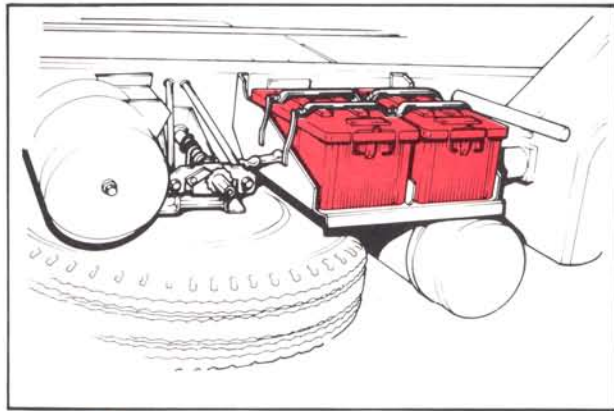

FA

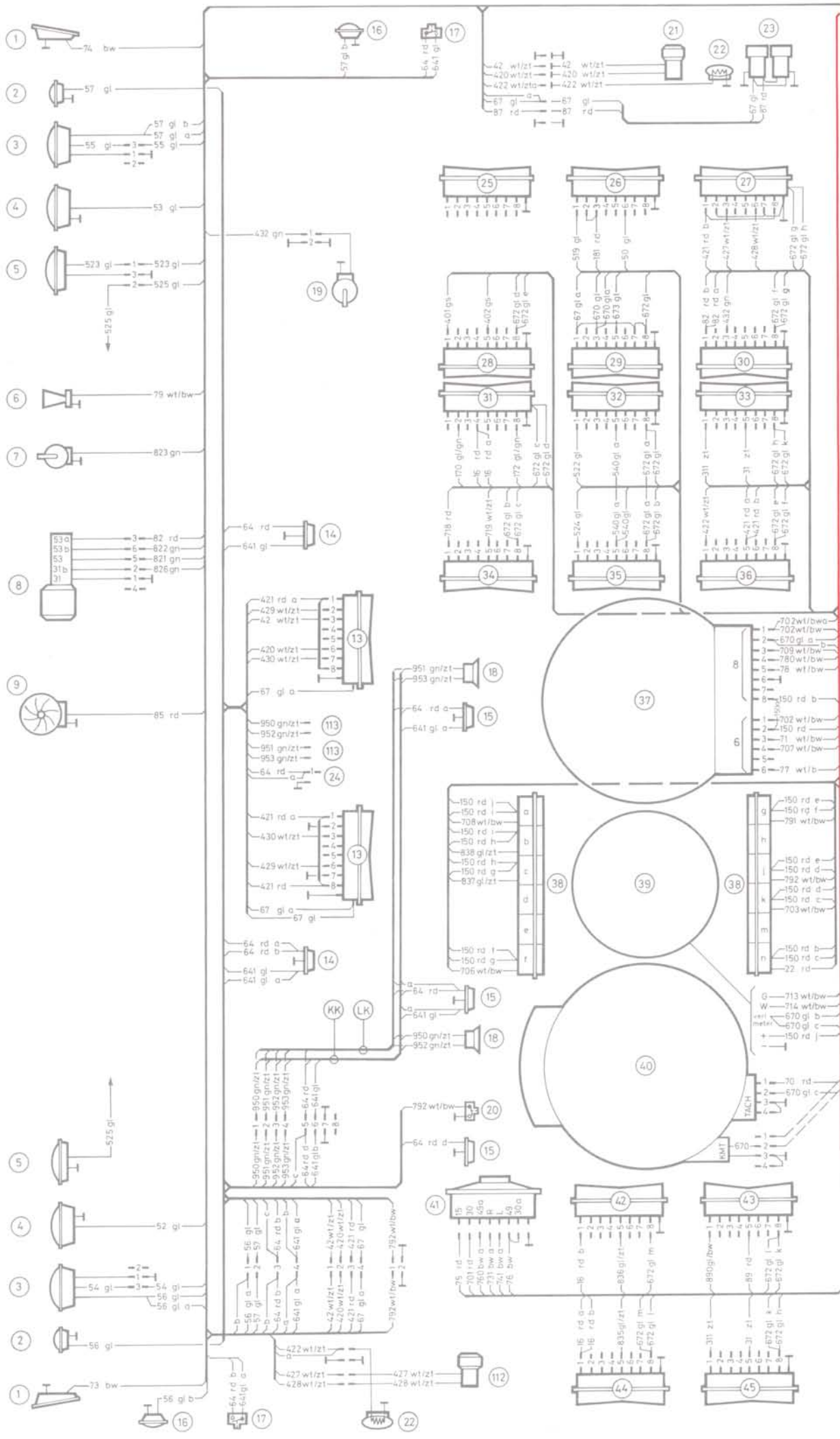

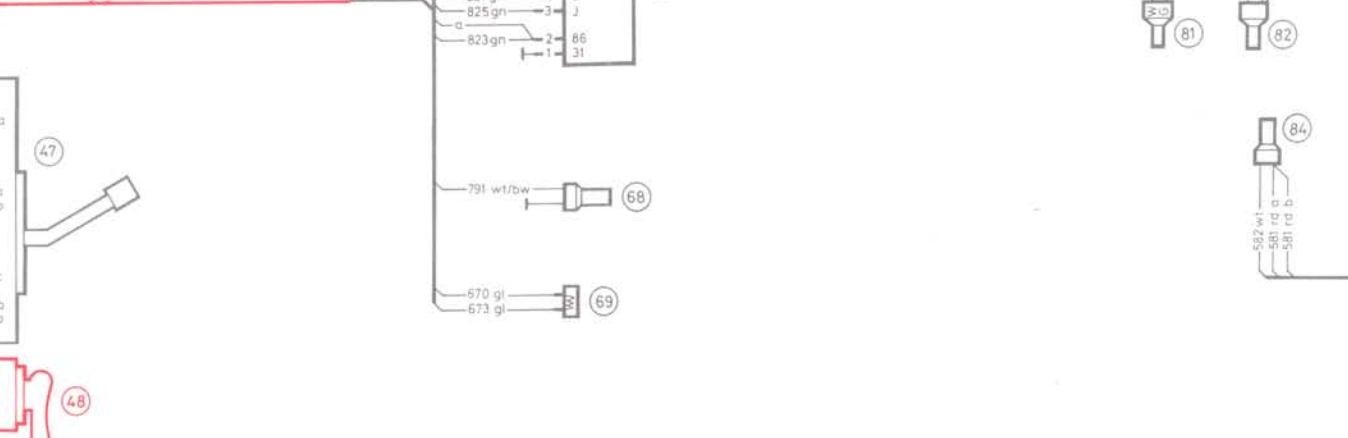
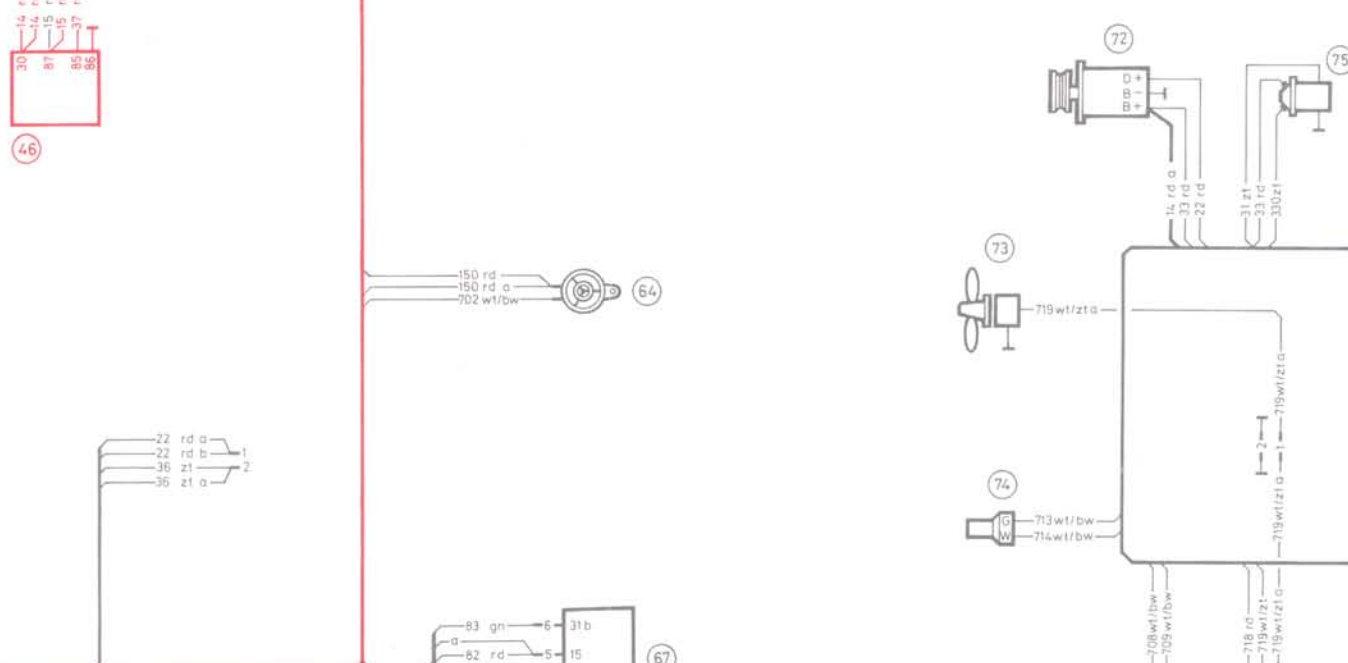
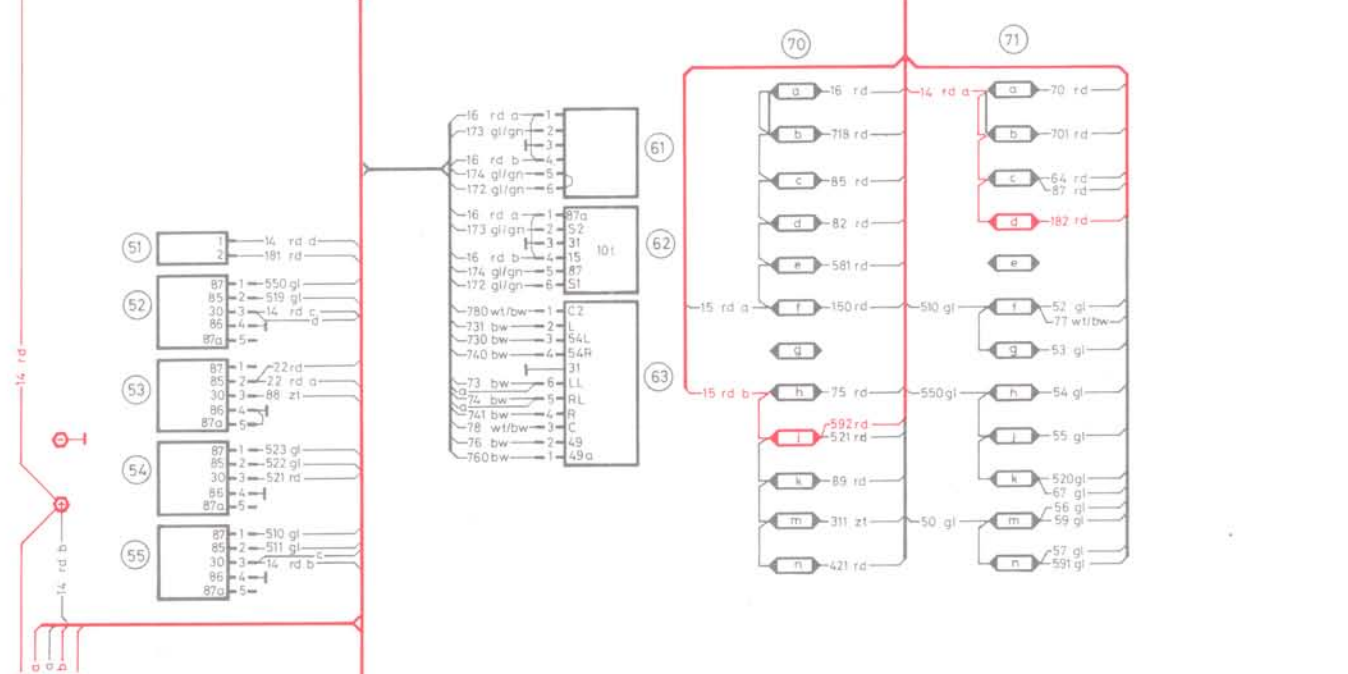
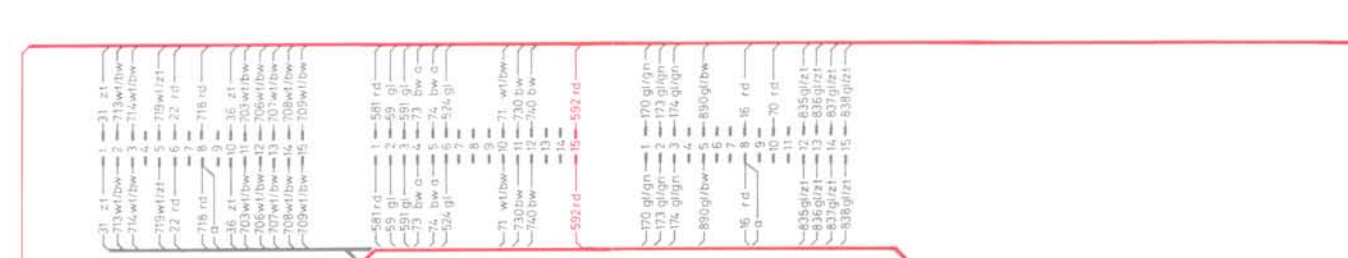
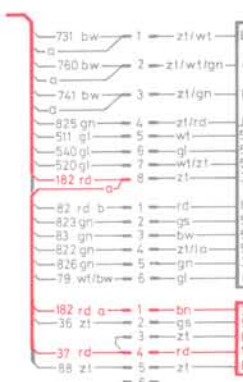
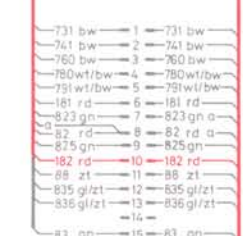
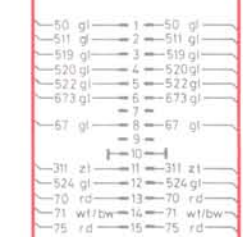
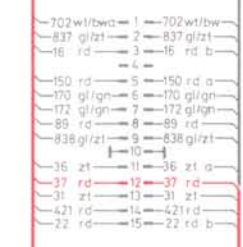
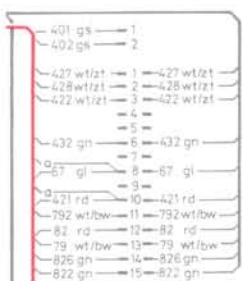

ACHTERUITRIJLAMP

Wordt door middel van de kontaktsleutel de stuurslot-kontaktschakelaar (48) verdraaid dan ontstaat de verbinding tussen de aansluitpunten 30 en 15 van deze schakelaar.

De spanning kan vanaf de batterijen via draad 14 rd, zekering (71)d, verbinding 30-15 van de stuurslot-kontaktschakelaar op aansluitpunt 85 van het kontaktrelais (46) komen.

Aansluitpunt 86 is met de massa verbonden dus zal dit relais bekrachtigd worden. Hierdoor wordt een verbinding gemaakt tussen de aansluitpunten 30 en 87 van dit relais en kan de spanning vanaf de batterijen via draad 14 rd, verbinding 30-87 van het kontaktrelais, zekering (70)i, op de schakelaar van het achteruitrijlicht (88) komen. Deze bevindt zich op de versnellingsbak. Wordt nu het voertuig in zijn "achteruit" gezet dan zal deze schakelaar zich sluiten en de lamp zal gaan branden.